

DAKOTA



THE EXCELLENCE OF WOOD
essenze naturali e nuances ricercate,
protagonista la materia
natural woods and sophisticated colours, matter is the star

DAKOTA

IMPERFETTO, PERFETTO: L'ECCELLENZA DEL LEGNO.

Imperfect, perfect: the excellence of wood.

Imparfait, parfait: l'excellence du bois.

Unvollkommen, vollkommen: Die Vorzüglichkeit von Holz.

Несовершенно, прекрасно: превосходство дерева.



LA MATERIA È LA NATURALE PROTAGONISTA DI QUESTA ESCLUSIVA COLLEZIONE DI PAVIMENTI E RIVESTIMENTI IN GRES PORCELLANATO, FIRMATA FLAVIKER.

Matter is the natural star of this exclusive collection of porcelain stoneware wall and floor tiling, by Flaviker _ La matière est le protagoniste naturel de cette collection exclusive de sols et de revêtements en grès cérame, signée Flaviker _ Die Materie ist der natürliche Mittelpunkt dieser exklusiven Kollektion aus Bodenbelägen und Verkleidungen aus Feinsteinzeug aus dem Hause Flaviker _ Предметом является естественный характер этой эксклюзивной коллекции напольных и облицовочных покрытий из керамогранита с фирменным знаком Flaviker.



TORTORA, NATURALE, AVANA E GRIGIO: LE COLORAZIONI DI SUCCESSO.

Tonalità naturali, ricercate e attuali, valorizzano la trama delle superfici e conferiscono agli spazi interni un'atmosfera calma e accogliente, dall'inconfondibile fascino moderno.

Per migliorare la qualità della vita e il rispetto dell'ambiente, i prodotti Flaviker sono realizzati secondo standard di sostenibilità sempre più elevati. Una gestione attenta dei processi produttivi che tutela il nostro patrimonio naturale e le persone che ne fanno parte, riaffermando il primato tecnologico del Made in Italy.



dakota tortora



dakota naturale



dakota avana



dakota grigio

TORTORA, NATURALE, AVANA AND GRIGIO: THE COLOURS OF SUCCESS. Current and sophisticated natural shades bring out the best in the surfaces and create interiors with a calm, welcoming atmosphere and an unmistakable modern charm. To improve the quality of life and respect the environment, Flaviker products are made to increasingly high standards of sustainability. Careful management of the production processes to protect our natural heritage and the people who live here, underlining the technological supremacy of Italian-made goods _ **TORTORA, NATURALE, AVANA ET GRIGIO : LES COLORIS DU SUCCÈS.** Des tonalités naturelles, recherchées et actuelles, valorisent la trame des surfaces et confèrent aux espaces intérieurs une atmosphère calme et accueillante, au charme moderne incomparable. Afin d'améliorer la qualité de la vie et le respect de l'environnement, les produits Flaviker sont réalisés suivants des standards de durabilité de plus en plus élevés. Une gestion attentive des processus de production qui protège notre patrimoine culturel et les personnes qui en font partie réaffirme la suprématie technologique du « Made in Italy » _ **TORTORA, NATURALE, AVANA UND GRIGIO: DIE ERFOLGREICHEN FARBEN.** Natürliche, ausgesuchte und aktuelle Farbtöne unterstreichen das Oberflächenmuster und verleihen den Innenräumen eine ruhige, behagliche Atmosphäre von unverwechselbarem modernem Reiz. Um die Lebensqualität und den Umweltschutz zu verbessern, werden die Produkte von Flaviker entsprechend immer höheren Nachhaltigkeitsstandards gefertigt. Eine aufmerksame Handhabung der Produktionsprozesse unter Schutz unseres Naturerbes und der Personen, die darin leben, wobei sich gleichzeitig die technologische Überlegenheit der italienischen Produktion zu behaupten weiß _ **TORTORA, NATURALE, AVANA И GRIGIO: ЦВЕТА УСПЕХА.** Натуральные оттенки, пользующиеся спросом и актуальные, усиливают ценность текстуры поверхностей и придают интерьерам спокойную и гостеприимную атмосферу с уникальным современным очарованием. В целях улучшения качества жизни и уважения к окружающей среде изделия компании Flaviker изготовлены в соответствии со стандартами экологической устойчивости, имеющими наиболее высокие требования. Тщательное управление производственными процессами, которое обеспечивает защиту нашего природного наследия и людей, которые являются его составной частью, подтверждает технологическое первенство Made in Italy.

DAKOTA



UNA ORIGINALE E AUTENTICA STORIA CONTEMPORANEA.

I nuovi formati 40x170 e 20x170 rettificati, conquistano gli spazi più ampi e prestigiosi nel residenziale e commerciale. La materia lascia emergere liberamente sulla superficie, nel segno di un forte realismo, tutte le naturali “imperfezioni” che diventano il tratto distintivo di un materiale in piena sintonia con le tendenze dell’interior design.

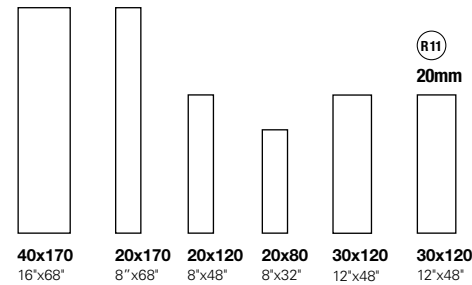

Original and authentic contemporary history. The new prestigious rectified sizes 40x170 and 20x170 are making more and more headway in residential and commercial sectors. Matter and all its natural “imperfections” emerge clearly and realistically on the surface, to become a distinguishing feature of a material in full harmony with modern interior design trends _ **Une histoire contemporaine originale et authentique.** Les nouveaux formats 40x170 et 20x170 rectifiés conquièrent les espaces les plus vastes et prestigieux dans les domaines résidentiel et commercial. La matière laisse émerger librement sur la surface, sous le signe d’un réalisme intense, toutes les « imperfections » naturelles qui deviennent le trait distinctif d’un matériau en pleine harmonie avec les tendances du design d’intérieur _ **Eine originelle, authentische zeitgenössische Geschichte.** Die neuen rektifizierten Formate 40x170 und 20x170 erobern im Wohn- und Gewerbebereich die größten, prestigereichsten Räume. Die Materie lässt im Zeichen eines starken Realismus alle natürlichen „Unvollkommenheiten“ frei auf der Oberfläche zum Vorschein kommen, die so zu einem Unterscheidungsmerkmal eines Materials werden, das vollkommen mit den Tendenzen des Innendesigns im Einklang steht _ **Подлинная и достоверная современная история.** Новые форматы 40x170 и 20x170, с идеально перпендикулярными сторонами и вертикальными краями, завоевывают пространства в наиболее крупных и престижных жилых и коммерческих комплексах. Материал позволяет свободно выделить на поверхности, под знаком глубокого реализма, все естественные “несовершенства”, которые становятся отличительной чертой материала в полной гармонии с тенденциями дизайна интерьера.

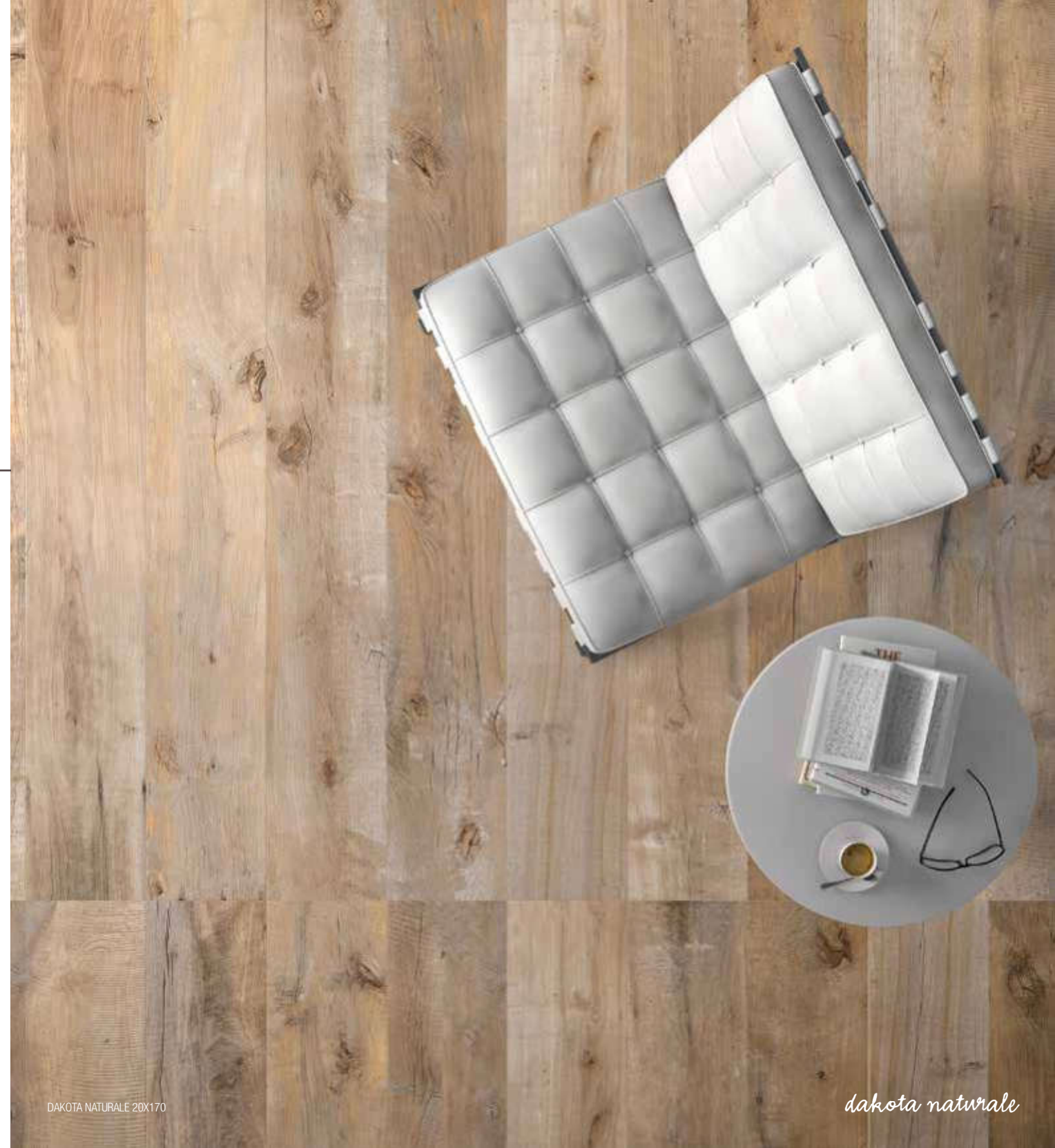



DAKOTA RESERVE TORTORA 20x120

La bellezza della natura aumenta le potenzialità applicative del pavimento anche outdoor. Le calde tonalità creano un contomo armonioso e sofisticato, una nuova sensazione di spazio _ The beauty of nature increases the application possibilities of flooring even outdoors. Warm shades create a sophisticated and harmonious setting, a new space sensation _ La beauté de la nature augmente les possibilités d'application du sol même à l'extérieur. Les tons chauds créent un contour harmonieux et sophistiqué, une nouvelle sensation d'espace _ Die Schönheit der Natur bietet weitere Anwendungsmöglichkeiten für die Bodenplatte im Freien. Mit den warmen Farbtönen wird eine harmonisch-elegante Einbettung erreicht, die neue Raumempfindungen erzeugt _ Красота природы расширяет возможность использования напольного покрытия, в том числе и для наружного оформления. Теплые оттенки создают гармоничный и утонченный интерьер, новое видение пространства.



dakota reserve grigio 20x120

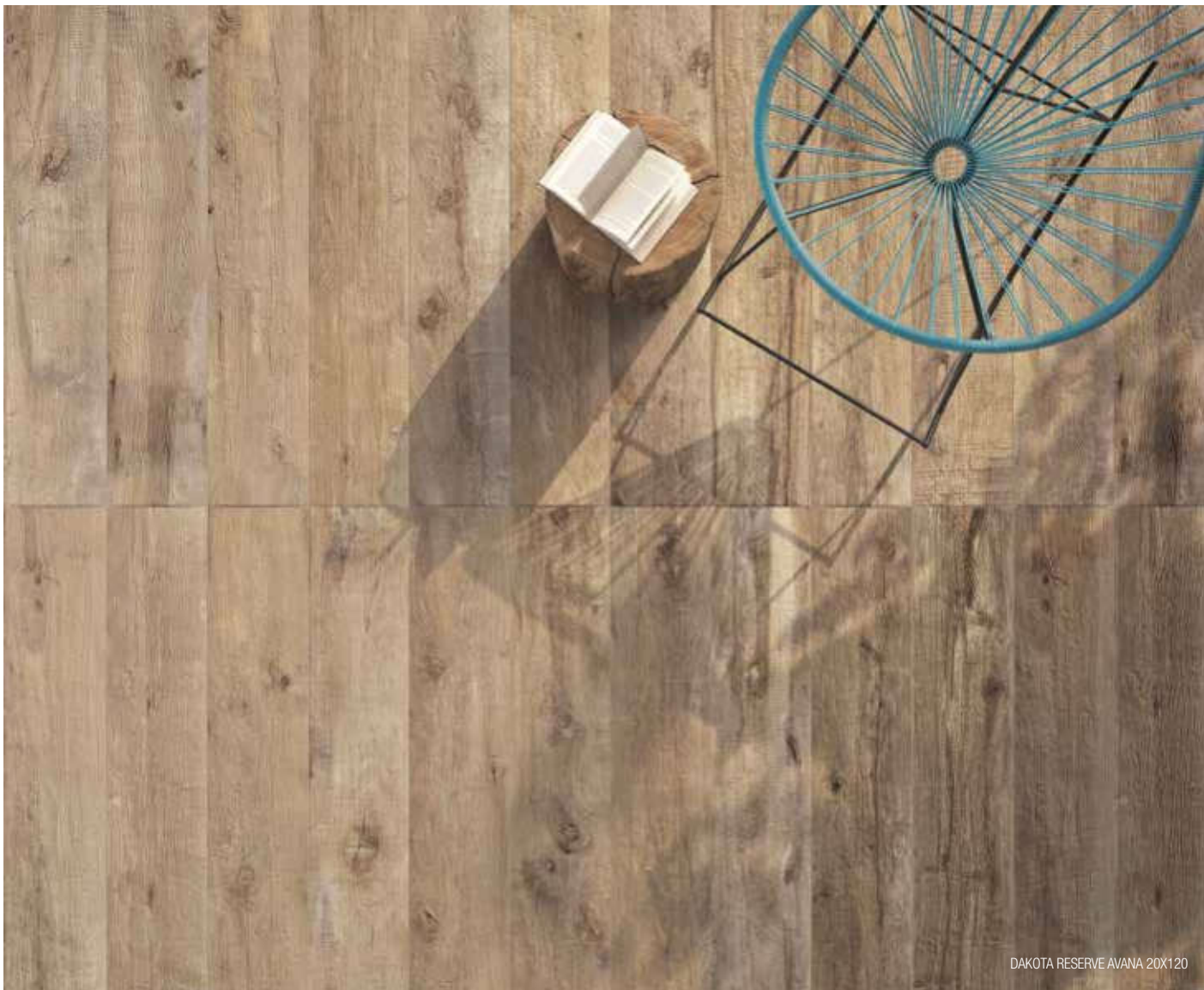

DAKOTA RESERVE AVANA 20X120

Per personalizzare con classe, la collezione Dakota offre soluzioni innovative all'insegna della ricercatezza. Una riuscita combinazione di fascino e creatività per un ambiente moderno esteticamente unico _ The Dakota collection offers innovative solutions inspired by refinement for a sophisticated customisation. A successful combination of fascination and creativity for an esthetically unique modern environment _ La collection Dakota offre des solutions innovantes très raffinées pour personnaliser avec goût vos pièces. Une alliance parfaite entre séduction et créativité pour un espace à l'allure moderne et unique _ Für individuelle, elegante Gestaltungslösungen bietet Dakota innovative und raffinierte Lösungen. Eleganz und Kreativität für ein ausgesprochen modernes und völlig einzigartiges Ambiente _ С тем, чтобы Вы могли стильно подчеркнуть свою индивидуальность, коллекция Dakota предлагает инновационные решения с ноткой утонченности. Удачное сочетание очарования и креативности для создания современного, уникального с точки зрения эстетики интерьера.

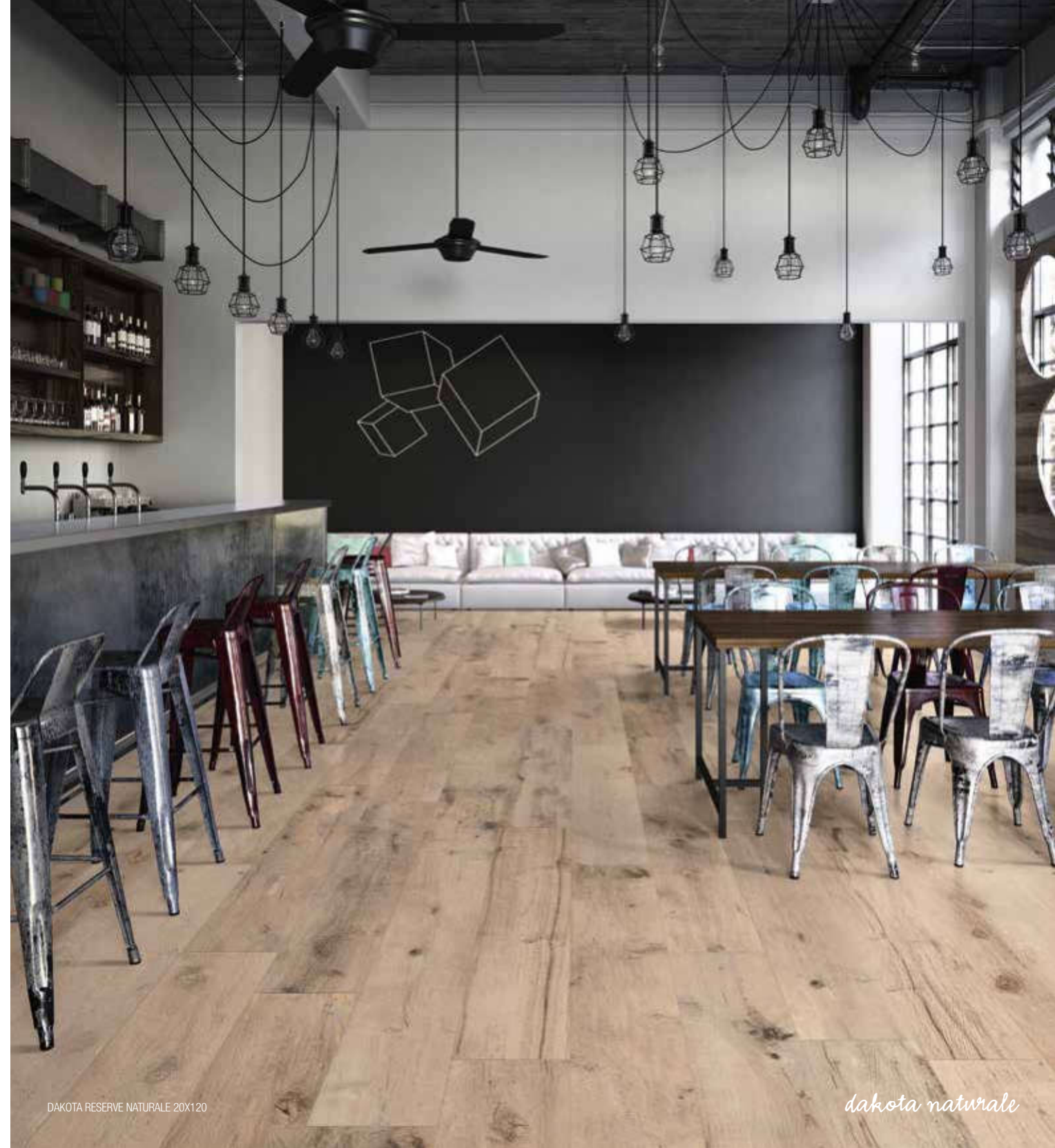

DAKOTA RESERVE NATURALE 20X120

dakota naturale



dakota avana

L'amore per la matericità del legno e per la purezza delle forme semplici, conferiscono agli interni contemporanei una bellezza senza tempo _ A love for the texture of wood and the purity of simple forms add timeless beauty to contemporary interiors _ L'amour pour la matérialité du bois et pour la pureté des formes simples confèrent aux intérieurs contemporains une beauté atemporelle _ Die Liebe für die materische Beschaffenheit von Holz und für die Reinheit der einfachen Formen verleiht den Innenräumen eine zeitlose Schönheit _ Любовь к текстуре дерева и к чистоте простых форм придают современным интерьерам непреходящую красоту.



DAKOTA AVANA 20X120_20X80



DAKOTA NATURALE 20x170_20x120



Superfici dal forte segno naturale e il look discreto degli arredi, sottolineano la calda e rilassante atmosfera dell'insieme. Surfaces with a highly natural appearance and the discreet design of the furnishings underline the generally warm and relaxed atmosphere. Les surfaces au signe naturel intense et le look discret des décorations soulignent la chaude et relaxante atmosphère de l'ensemble. Oberflächen mit starken natürlichen Merkmalen und der diskrete Look der Einrichtungen unterstreichen die warme, entspannende Atmosphäre des Ganzen. Поверхности с глубоким натуральным отпечатком и сдержанный внешний вид мебели подчеркивают теплую и расслабляющую атмосферу в целом.

dakota naturale

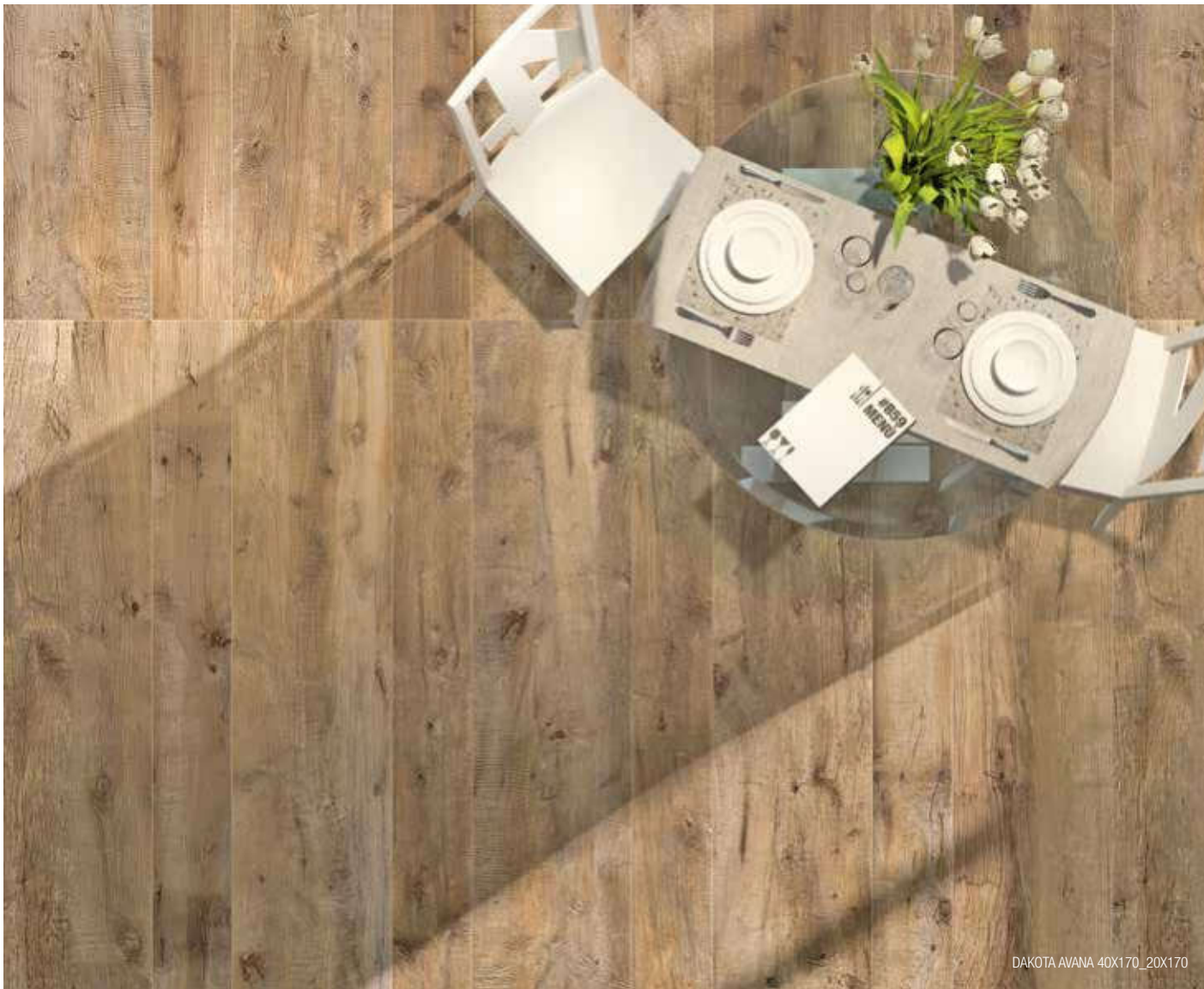

DAKOTA AVANA 40X170_20X170

dakota avana

Texture in simbiosi con la natura, catturano le emozioni e con la loro apparente semplicità, diventano le assolute protagoniste di nuovi stili di vita _ Textures in harmony with nature capture emotions and, with their apparent simplicity, become the clear stars of new lifestyles _ Les textures, en symbiose avec la nature, capturent les émotions et, avec leur simplicité apparente, deviennent les protagonistes absolues de nouveaux styles de vie _ Texturen, die in Symbiose mit der Natur leben, ziehen die Gefühle auf sich und werden mit ihrer scheinbaren Einfachheit zu den absoluten Mittelpunkten von neuen Lebensstilen _ Текстура в симбиозе с природой пленяют эмоции и вместе с их кажущейся простотой, становятся абсолютными главными персонажами нового образа жизни.



DAKOTA TORTORA 40X170_20X170

dakota tortora



dakota grigio/tortora

DAKOTA TORTORA 20X80
DAKOTA GRIGIO LISTELLATO 3D 20X80

Tonalità calde e intense valorizzano gli ambienti dedicati al relax e infondono una nuova energia agli spazi della casa _ Warm, intense shades underline settings devoted to relaxation, spreading new energy throughout the home _ Les tonalités chaudes et intenses valorisent les environnements consacrés à la détente et insufflent une nouvelle énergie aux espaces de la maison _ Warme, intensive Farbtöne bringen der Entspannung gewidmete Umgebungen zur Geltung und flößen den Wohnräumen eine neue Energie ein _ Теплые и глубокие оттенки раскрывают потенциал помещений, предназначенных для отдыха, и вселяют новую энергию в пространства дома.



DAKOTA TORTORA 20X80
DAKOTA GRIGIO LISTELLATO 3D 20X80



DAKOTA AVANA 20X170



dakota avana

Esenze naturali e nuance ricercate: la materia si arricchisce di nuovi contenuti creativi effetto legno, per arredare spazi e creare atmosfere di nuova domesticità _ Natural woods and sophisticated colours: matter takes on new wood-effect creative contents to decorate spaces and create new cosy domestic atmospheres _ Des essences naturelles et des nuances recherchées : la matière s'enrichit de nouveaux contenus créatif effet bois pour décorer les espaces et créer des atmosphères de nouvelle domesticité _ Natürliche Holzarten und ausgesuchte Nuancen: Die Materie wird um neue kreative Inhalte mit Holzoptik bereichert, um Räume einzurichten und Atmosphären einer neuen Häuslichkeit zu schaffen _ Naturalные породы дерева и утонченные нюансы: материал обогащается новым творческим содержанием эффекта дерева, обставляя пространства и создавая атмосферу новой интимности.



Formati e soluzioni di posa, trame e colori si inseriscono con naturale semplicità ed eleganza nei progetti, per esprimere nuovi concept estetici nell'interior design _ Sizes and laying solutions, patterns and colours work together in the designs naturally, simply and elegantly, expressing new aesthetic concepts for interior design _ Les formats et les solutions de pose, les trames et les couleurs s'insèrent avec une simplicité naturelle et une élégance dans les projets afin d'exprimer de nouveaux concepts esthétiques dans le design d'intérieur _ Formate und Verlegelösungen, Muster und Farben fügen sich mit natürlicher Einfachheit und Eleganz in die Projekte ein, um neue ästhetische Konzepte im Innendesign zum Ausdruck zu bringen _ Форматы и решения по кладке, текстуры и цвета сочетаются с природной простотой и элегантностью в проектах для выражения новых эстетических концепций дизайна интерьера.



dakota tortora/grigio



DAKOTA TORTORA 40X170_ 20X170
DAKOTA GRIGIO 20X170



La dimensione straordinaria del materiale esalta gli spazi e propone soluzioni dal forte impatto visivo _ The extraordinary size of the material makes the most of the spaces, proposing solutions with a strong visual impact _ La dimension extraordinaire du matériau exalte les espaces et propose des solutions au fort impact visuel _ Die außerordentliche Größe des Materials bringt die Räume zur Geltung und bietet Lösungen von starker optischer Wirkung _ Необычный размер материала подчеркивает пространство и предлагает решения с сильным зрительным эффектом.



DAKOTA: TORTORA 40x170 - TORTORA RESERVE 20x120
SUPREME: SILVER DREAM ANTICATO RETT. 60x120 - MIX SIZES 30x120
ROYAL STATUARIO ANTICATO RETT. 60x120 - MIX SIZES 30x120

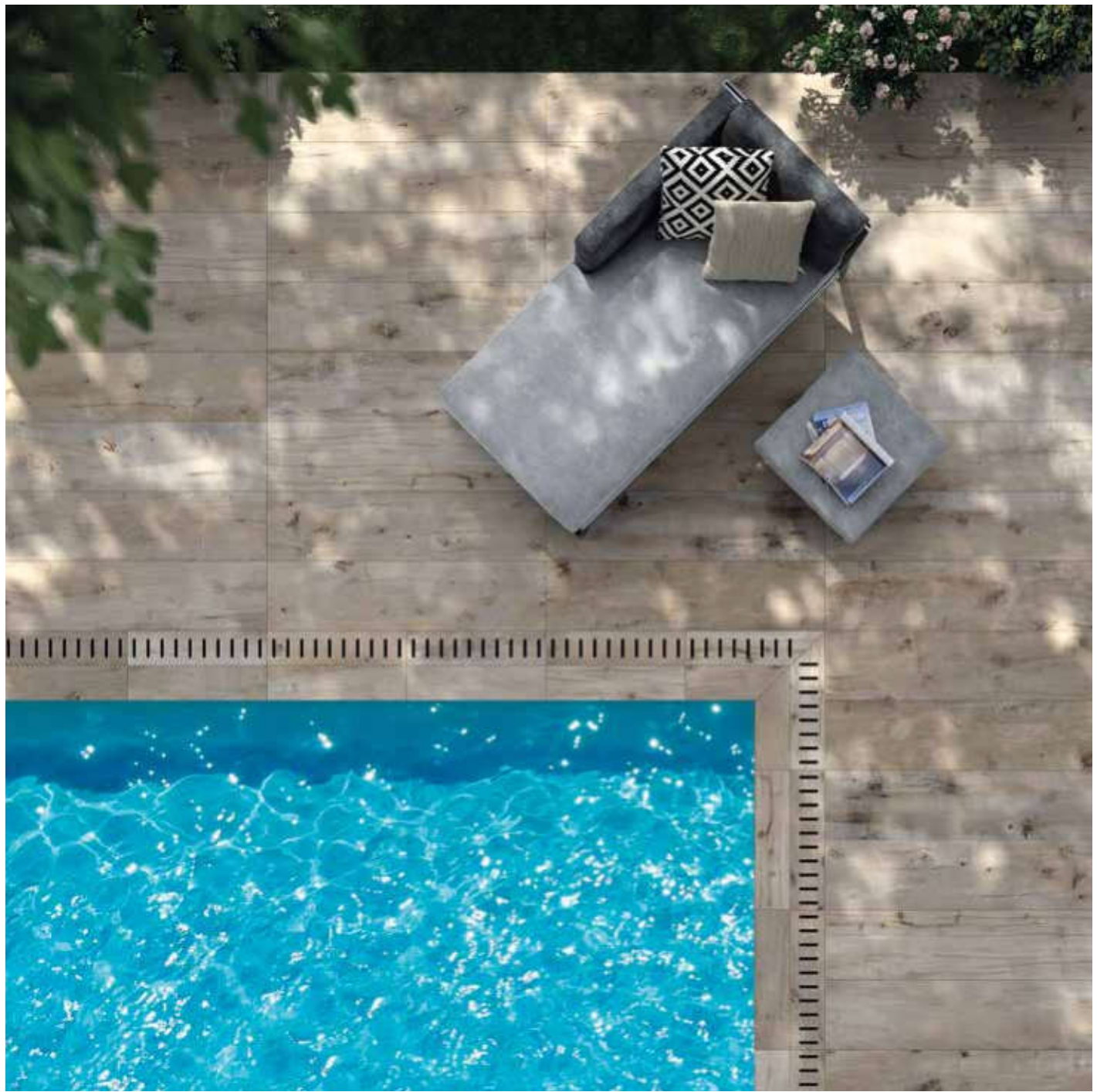

DAKOTA NATURALE 30x120 20 mm

NATURALE

AVANA



R: Rettificato | Rectified
S: Reserve Rettificato | Rectified

*Per la serie completa vedi pag.170 | For the complete collection see page 170

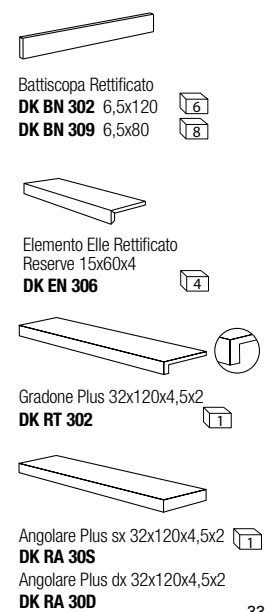
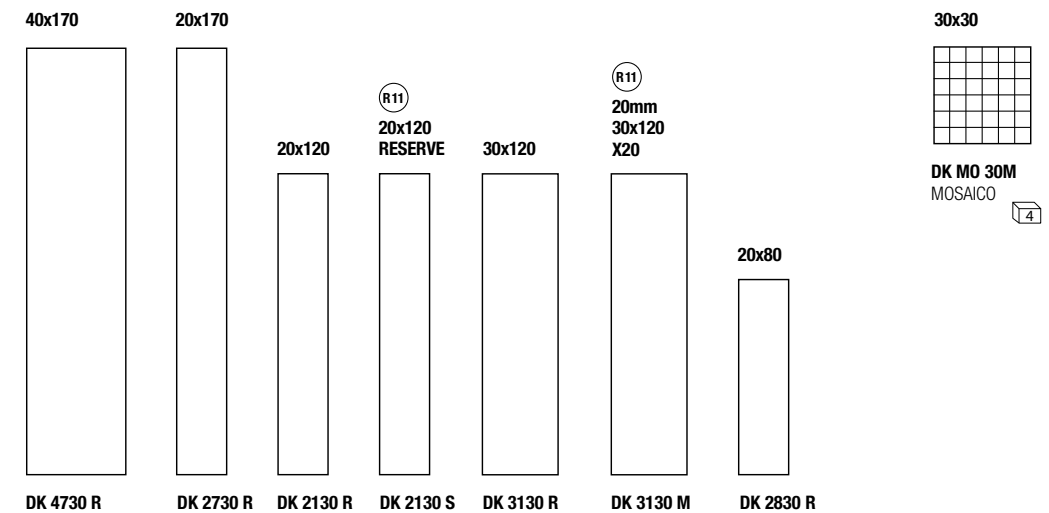
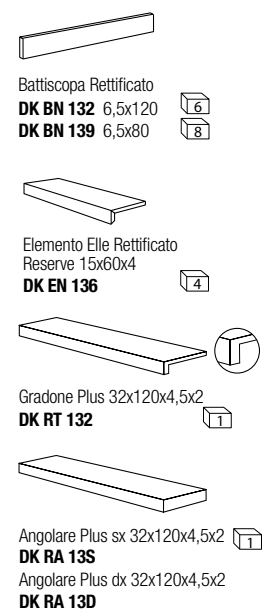
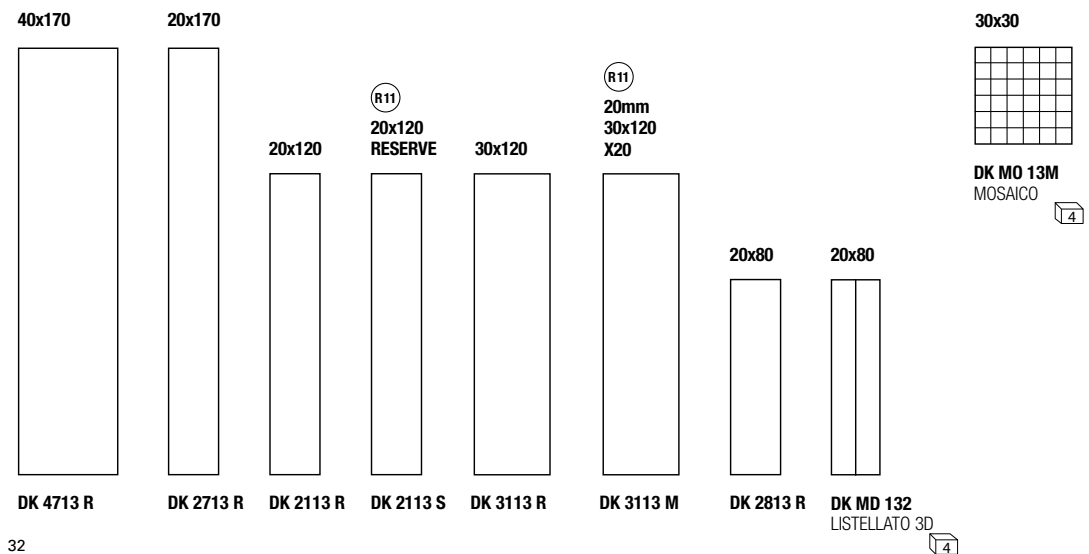

GRIGIO

TORTORA



R: Rettificato | Rectified
S: Reserve Rettificato | Rectified

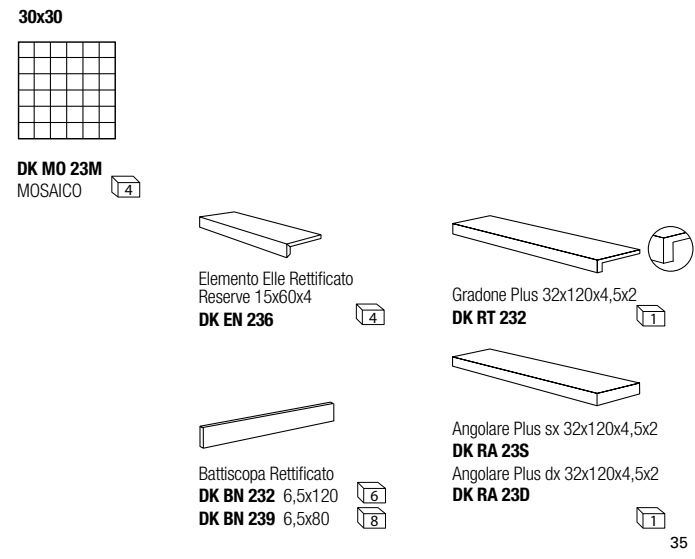
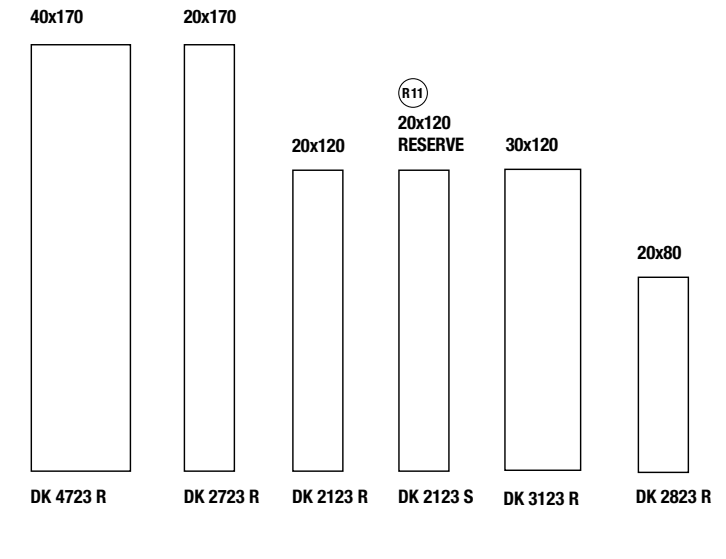
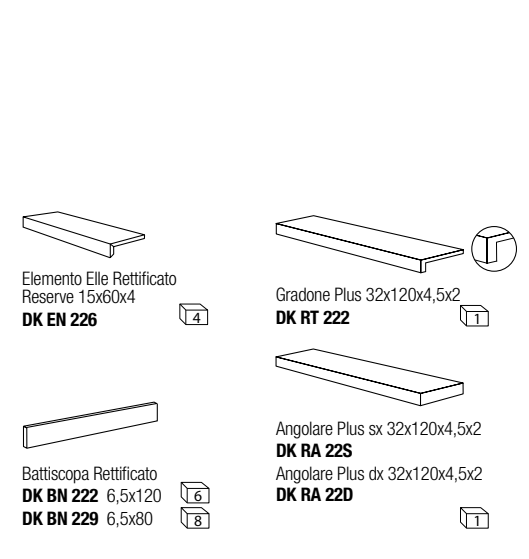
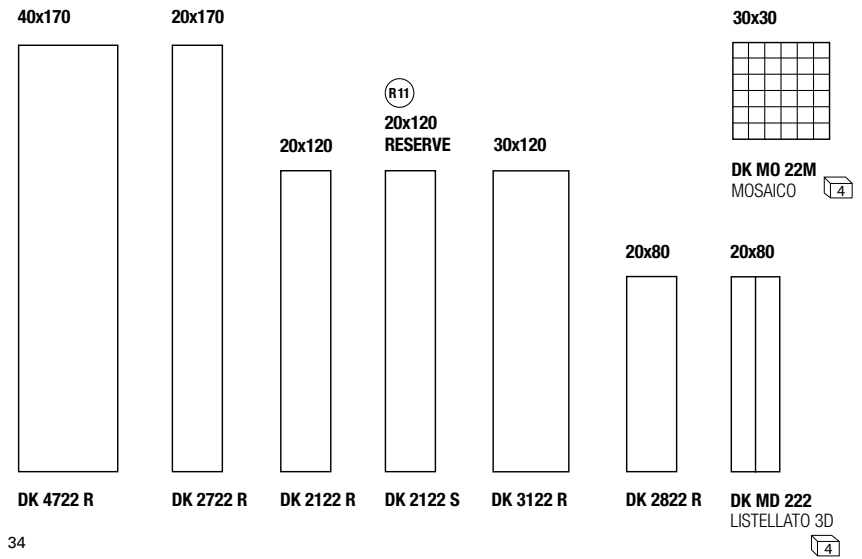

R: Rettificato | Rectified
S: Reserve Rettificato | Rectified

AUTO-LEVELING™

 **Facile installazione - Easy laying**

All'interno delle proprie collezioni più prestigiose FLAVIKER dà spazio ai grandi formati rettificati 40x170, corredati dai sottomultipli 20x170 e 20x120. La produzione di questi formati avviene utilizzando materie prime ad elevata plasticità, che permettono di ottenere lastre particolarmente flessibili. Questa flessibilità consente di ottenere una convessità tale da facilitarne la posa, ed una maggiore adattabilità alle condizioni del sottofondo. Una volta posate queste piastrelle si auto-livellano, l'installazione risulta più semplice e, indipendentemente dallo schema di posa, la superficie risulterà sempre perfettamente planare.

In its most prestigious collections, FLAVIKER also includes large 40x170 porcelain tileslabs, completed with matching 20x170 and 20x120 subformats tiles. These larger sizes are produced using raw materials characteried by high plasticity, which enables the slabs to be particularly flexible. This flexibility translates into a minimum level of convexity which facilitates installation, enabling greater adaptability to substrate conditions. When laid, these tiles self-level, the installation is easier and, regardless the laying pattern, the surface will be always perfectly leveled.



Lastre prodotte con materie prime ad elevata plasticità, resistenti ma flessibili.

Ceramic slabs manufactured with highly plastic raw materials, strong and flexible at the same time.



Appoggiate su qualsiasi superficie, anche non perfettamente planare, le lastre si auto-livellano.

Laid on the screed they self-level, even if the surface is not perfectly flat.



Il prodotto auto-leveling agevola la posa tradizionale, si monta senza distanziali livellanti, seguendo qualsiasi schema di posa.

Auto-leveling tiles help the traditional fixing, every installation pattern can be achieved, without leveling spacers.

INDICATORE DI FLESSIBILITA' FLEXIBILITY INDEX	DEFLESSIONE MASSIMA SOTTO CARICO DI 350 N MAXIMUM DEFLECTION UNDER LOAD OF 350 N	LATO/LENGHT 1200mm	> 20 mm
		LATO/LENGHT 1700mm	> 30 mm

INSTA-TILE



Le lastre Auto-Leveling nel formato 20x170 possono essere montate seguendo il sistema Insta-Tile, un nuovo metodo di posa a secco che consiste nel fissaggio del materiale direttamente sul pavimento preesistente, senza alcuna opera di demolizione. Dopo aver steso un tappetino in sughero o polietilene dello spessore di circa 2 mm, si consiglia di posizionare una serie di distanziali di 5 mm lungo tutte le pareti interessate per poi proseguire con la posa delle piastrelle, a giunto unito, praticando tutti i tagli necessari fino a coprire completamente il vecchio pavimento. Per contenere le dilatazioni si consiglia di applicare qualche goccia di silicone lungo il perimetro, per poi rimuovere i distanziali e procedere con l'inserimento del profilo o del battiscopa. Il nuovo pavimento, la cui superficie risulterà perfettamente planare anche senza l'utilizzo di colle e sigillanti e potrà facilmente essere rimosso e recuperato in qualsiasi momento.

Our 20x170 auto-leveling slabs can be laid using the Insta-Tile system, which is a new dry-fixing method that consists in laying the tiles directly on top of the existing floor, without any scrapping or removal work. After laying an approximately 2 mm thick cork or polyethylene underlayer, we recommend you fit a series of 5 mm spacers along all the perimeter before laying the tiles. The tiles should be laid with a closed joint and cut where necessary to completely cover the old floor. To limit expansion, it is recommended to apply a few drops of silicon around the outer edge, then remove the spacers and fit the edge trim or the skirting. The new floor, whose surface should be perfectly flat even without the use of glues or sealants, can be removed and re-used at any time.

OPERAZIONI DI POSA INSTA-TILE INSTA-TILE LAYING PROCESS



1 Eliminare il battiscopa
Remove skirting



2 Stendere il tappetino
Lay the underlayer



3 Posizionare i distanziali lungo il perimetro
Fit the spacers around the outer edge



4 Posare il pavimento senza fuga
Lay the floor tiles with close joints



5 La superficie risulterà perfettamente planare
The finished floor will be perfectly flat



Installazione prevista esclusivamente con prodotti AUTO-LEVELING nel formato 20x170.

You should use AUTO-ONLY products in the 20x170 size.



Installazione adatta unicamente ad ambienti INDOOR.

This system can be used for INDOORS installation only.



Si sconsiglia l'utilizzo di INSTA-TILE negli ambienti maggiormente umidi o sporchevoli, come bagno e cucina.

INSTA-TILE is not recommended in wet or easily dirtied areas, such as bathrooms and kitchens.



Il metodo INSTA-TILE permette di stendere le lastre senza alcuna fuga.

AUTO-LEVELLING tiles can be installed with close joints.



L'applicazione può avvenire in diverse situazioni:

- su massetto in cemento
 - su massetto in cemento con impianto di riscaldamento
 - su pavimento preesistente in ceramica, legno o linoleum
 - su pavimento preesistente con impianto di riscaldamento
- In tutti questi casi dev'essere utilizzato un materassino in sughero o in polietilene su cui stendere le lastre. E' possibile direttamente su moquette di basso spessore senza l'ausilio del materassino.

It can be laid in different solutions:

- on top of cement screeds,
 - on top of cement screeds with heating systems
 - on top of existing ceramic, wooden or linoleum floorings
 - on top of existing floorings with heating systems
- In all these cases, a cork or polyethylene underflooring must be used. The planks can also be laid directly on top of short-pile carpet, without needing the underflooring.



Il pavimento INSTA-TILE si può pulire con normali detersivi, utilizzando regolarmente il panno bagnato ed i vari sistemi mop. Nel caso di versamento importante di liquidi, sollevare le lastre ceramiche nella zona interessata aiutandosi con una ventosa, asciugare o sostituire la porzione del materassino sottostante e riposizionare le piastrelle.

INSTA-TILE flooring can be cleaned with normal cleaning detergents, using a wet cloth or a traditional mop. In the event of major spills, lift up the ceramic tiles in the affected area using a suction cup, dry or replace the area of underflooring below and refit the tiles.



Si sconsiglia l'utilizzo di INSTA-TILE in presenza di animali domestici.

We do not recommend use of the INSTA-TILE system in homes with pets.

Per maggiori informazioni sulla tecnologia Auto-leveling e sul sistema di posa Insta-Tile puoi effettuare il download del filmato ufficiale di presentazione su www.flavikerpisa.it
For further information on Auto-leveling technology and the Insta-Tile installation system, download the official presentation video on the website www.flavikerpisa.it

GRES PORCELLANATO A MASSA COLORATA_FULL BODY COLOURED PORCELAIN STONWARE

PAVIMENTI FLOOR TILES SOLS BODENFLIESEN		CLASSIFICAZIONE SECONDO NORME CLASSIFICATION IN ACCORDANCE WITH CLASSIFICATION SELON LES NORMES KLASSIFIZIERUNG GEMÄSS	EN 14411 EN 14411 EN 14411 EN 14411	ALLEGATO G ANNEXE G ANNEXE G NORMEN ANLAGE G	GRUPPO GRUPPO GRUPPE GROUPE	B I a B I a B I a B I a	 CONTEMPORARY ECO CERAMICS	
PROPRIETÀ FISICO-CHIMICHE PHYSICAL-CHEMICAL PROPERTIES PROPRIÉTÉS PHYSICO-CHIMIQUES PHYSIKALISCH-CHEMISCHE EIGENSCHAFTEN		TIPO DI PROVA STANDARD OF TEST NORME DU TEST TESTNORM	VALORE PRESCRITTO REQUIRED VALUE VALEUR PRESCRITE VORGESCHRIEBENER WERT		NATURALE VALORE MEDIO MEAN VALUE VALEUR MOYENNE MITTELWERT	RESERVE VALORE MEDIO MEAN VALUE VALEUR MOYENNE MITTELWERT		
DIMENSIONI sizes dimensions Abmessungen	UNI EN ISO 10545.2	LUNGHEZZA E LARGHEZZA LENGTH AND WIDTH LONGUEUR ET LARGEUR LÄNGE UND BREITE SPESORE THICKNESS ÉPAISSEUR STÄRKE RETTILINEITÀ SPIGOLI LINEARITY RECTITUDE DES ARÊTES KANTENGERADHEIT ORTOGONALITÀ WEDGING ORTHOGONALITÉ RECHTWINKLIGKEIT PLANARITÀ WARPAGE PLANÉITÉ EBENFLÄCHIGKEIT	± 0,6% max ± 5% max ± 0,5% max ± 0,6% max ± 0,5% max	CONFORME ACCORDING TO CONFORME EUFÜLLT	CONFORME ACCORDING TO CONFORME EUFÜLLT			
ASSORBIMENTO D'ACQUA water absorption absorption d'eau Wasseraufnahme	UNI EN ISO 10545.3	≤ 0,5 %		< 0,3%	< 0,3%			
RESISTENZA ALLA FLESSIONE flexion resistance résistance à la flexion Biegefestigkeit	UNI EN ISO 10545.4	MODULS OF ROPTURE: MINIMUM 35 N/mm ²		≥ 45 N/mm ²	≥ 45 N/mm ²			
RESISTENZA ALL'ABRASIONE PROFONDA resistance to deep abrasion résistance à l'abrasion Abriebhärte	UNI EN ISO 10545.6	≤ 175/mm ³		CONFORME ACCORDING TO CONFORME EUFÜLLT	CONFORME ACCORDING TO CONFORME EUFÜLLT			
COEFFICIENTE DI DILATAZIONE TERMICA LINEARE coefficient of linear thermal-expansion/lineare coefficient linéaire de dilatation thermique Wärmeausdehnungskoeffizient	UNI EN ISO 10545.8	≤ 9 (10 - 6/K)		≤ 6 (10 - 6/K)	≤ 6 (10 - 6/K)			
RESISTENZA AGLI SBALZI TERMICI resistance to thermal shock résistance aux variations thermiques Temperaturwechselbeständigkeit	UNI EN ISO 10545.9	TEST METHOD AVAILABLE		GARANTITA GUARANTEED GARANTIE GARANTIERT	GARANTITA GUARANTEED GARANTIE GARANTIERT			
RESISTENZA AL GELO frost resistance résistance au gel Frostbeständigkeit	UNI EN ISO 10545.12	NON DEVONO PRESENTARE ROTTURE O ALTERAZIONI APPREZZABILI DELLA SUPERFICIE MUST NOT PRODUCE NOTICEABLE ALTERATION TO SURFACE NE DOIVENT PAS PRÉSENTER DES RUPTURES OU ALTERATIONS TROP IMPORTANTES DE LA SURFACE OBERFLÄCHEN DÜRFEN KEINEN BRUCH ODER SCHADEN AUFWEISEN		RESISTENTE RESISTANT RESISTENT BESTÄNDIG	RESISTENTE RESISTANT RESISTENT BESTÄNDIG			
RESISTENZA AI PRODOTTI CHIMICI chemical resistance résistance aux produits chimiques Chemikalienfestigkeit	UNI EN ISO 10545.13	CLASS UB min CLASS GB min		CLASS UA min CLASS GA min	CLASS UA min CLASS GA min			

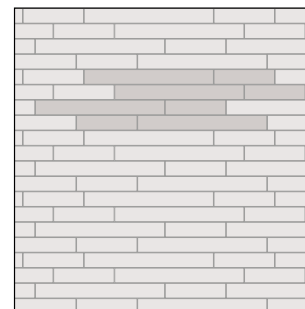

20x170 68%
20x80 32%

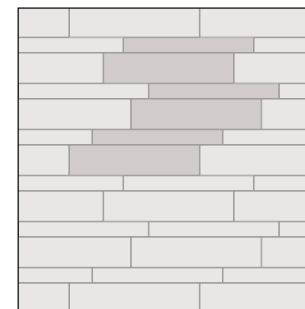

40x170 66,7%
20x170 33,3%

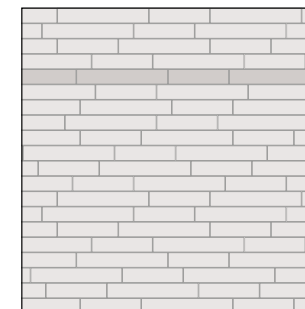

20x80 40%
20x120 60%

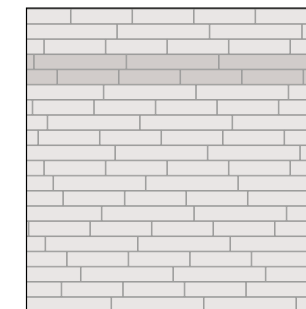

20x120 50%
20x80 50%

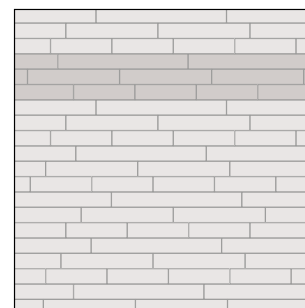

20x170 33,33%
20x120 35,30%
20x80 31,37

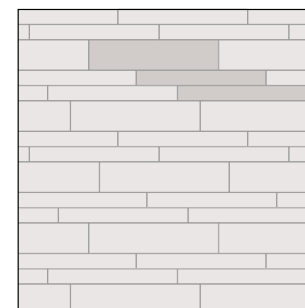

40x170 50%
20x170 50%

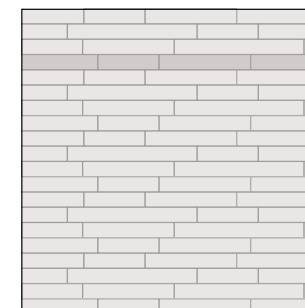

20x120 32,43%
20x170 45,94%
20x80 21,62%

ANTISDRUCCIOLO NON-SLIP				
PROPRIETÀ FISICO-CHIMICHE Physical-chemical properties	TIPO DI PROVA Standard of test	VALORE PRESCRITTO Required value	VALORE MEDIO Mean value	VALORE MEDIO Mean value
COEFFICIENTE D'ATTRITO STATICO Coefficient of static friction	Slip Resistant (≥ 0,60)	Slip Resistant (≥ 0,60)	≥ 0,60 DRY ≥ 0,60 WET	≥ 0,60 DRY ≥ 0,60 WET
COEFFICIENTE D'ATTRITO DINAMICO Dynamic friction coefficient	μ 0,19 Scivolosità pericolosa Dangerous slippery 0,20 < μ < 0,39 Scivolosità eccessiva Excessively slippery 0,40 < μ < 0,74 Attrito soddisfacente Satisfactory grip	μ 0,19 Scivolosità pericolosa Dangerous slippery 0,20 < μ < 0,39 Scivolosità eccessiva Excessively slippery 0,40 < μ < 0,74 Attrito soddisfacente Satisfactory grip	> 0,40 DRY	> 0,40 DRY
CLASSIFICAZIONE ANTISDRUCCIOLO Non-slip classification	DIN 51130	IN FUNZIONE DELL'AMBIENTE O DELLA ZONA DI LAVORO Basing on the environment or the working area	R 10	R 11
	DIN 51097	ANGOLO MEDIO DI SCIVOLAMENTO Corner middle of slipping ≥ 12 < 18 A ≥ 18 < 24 B ≥ 24 C	A+B	A+B+C
	ANSI A 137-1:2012	> 0,42	> 0,42	> 0,42

L'unità minima di vendita per tutti gli articoli (fondi, decori e pezzi speciali) è la scatola completa. The minimum sales quantity for all items (plain tiles, decorations and special trims) is one full box.

I pezzi speciali, per effetto delle lavorazioni, possono presentare variazioni di tonalità. Due to working process, special trims may show variations in tonality.

formato nominale nominal sizes	formato reale rettificato real rectified sizes	spessore thickness	pcs/box	m ² /box	kg/box	box/pallet	m ² /pallet	kg/pallet
40x170	40x170	9	2	1,36	27,00	32	43,52	908
20x170	19,9x170	9	4	1,36	27,00	36	48,96	1016
30x120	29,7x119,4	9	4	1,44	27,20	18	25,92	509
20x120	19,9x119,4	9	4	0,96	18,20	54	51,84	1008
20x120 Reverse	19,9x119,4	9	4	0,96	18,20	54	51,84	1008
20x80	19,9x80	9	8	1,28	24,00	42	57,36	1028

I dati relativi agli imballi sono aggiornati al momento della stampa del catalogo e pertanto possono subire variazioni nel corso del tempo.

Data referring to packaging have been update at time of printing; the actual data may be slightly different.



LA GARANZIA DI UN FUTURO GREEN BUILDING PASSA ATTRAVERSO LA QUALITA' ECO-SOSTENIBILE.

Da azienda sensibile alle tematiche ambientali, FLAVIKER si è sempre preoccupata di mantenere i parametri che regolano i processi industriali al di sotto delle normative, composto al 40% minimo da materiale riciclato recuperato da altre lavorazioni industriali. ECO-BODY è ufficialmente certificato per recepire gli standard LEED (Leadership in Energy and Environmental Design) il sistema di rating internazionale delle performance ambientali che in edilizia promuove la progettazione sostenibile riguardante l'intero edificio per ridurne l'impatto ambientale per tutto il suo ciclo di vita. Tutte le collezioni FLAVIKER che utilizzano questo speciale impasto certificato, riportano nella pagina riepilogativa l'esclusivo logo ECO-BODY, che oltre ad indicare il 40% minimo di materiale riciclato, ne evidenziano la compatibilità col sistema di crediti LEED.

FLAVIKER è membro di GREEN BUILDING COUNCIL ITALIA, l'associazione italiana dei leader che operano per trasformare il mercato dell'edilizia verso la sostenibilità ambientale e per costruire comunità vivibili. I soci GBC Italia promuovono la responsabilità ambientale, economica e sociale innovando il modo in cui gli edifici sono progettati, realizzati e utilizzati.

THE FUTURE OF GREEN BUILDING IS GUARANTEED BY ECO-SUSTAINABLE QUALITY.

As a company that cares deeply about environmental issues, FLAVIKER has always endeavoured to keep its parameters below the legal limits for manufacturing processes, utilising a minimum of 40% recycled material recovered from other industrial processes. ECO-BODY is officially certified for access to LEED (Leadership in Energy and Environmental Design) credits, the international rating system for environmental performance which promotes sustainable design in the construction industry with a view to reducing the overall environmental impact of buildings over their entire life cycle.

All FLAVIKER collections made with this special certified mix are identified in the contents page with the exclusive ECO-BODY logo, which in addition to indicating a minimum of 40% recycled material, underlines the product's compatibility with the LEED credits system. FLAVIKER is a member of Italian GREEN BUILDING COUNCIL, the association of top players working to transform the building market towards sustainability and to build liveable communities. GBC Italian members promote environmental, economic and social responsibility, innovating buildings in terms of engineering, design, manufacturing and use.

The system is based on credits awarded for each of the sustainability requirements met by the building. The sum of the credits determines the level of certification obtained.

Although LEED certification is awarded to buildings and not single products, ceramic tile products contribute to the achievement of LEED credits.

La riproduzione dei colori è approssimativa.

Colour reproduction approximate.

FLAVIKER S.S. 569 per Vignola, 226 41014 Solignano di Castelvetro (Mo) Italy T +39 (0) 59 9752011 F +39 (0) 59 9752010 flavikerpisa.it

FLAVIKER

CONTEMPORARY ECOCERAMICS

FLAVIKER

S.S. 569 per Vignola, 226
41014 Solignano di Castelvetro (Mo) Italy
T +39 (0) 59 9752011
F +39 (0) 59 9752010

flavikerpisa.it