

TECHNICAL SPECIFICATION:

Supply and installation of supports for raised floors type "NM", adjustable in height, equipped with bi-material head, with anti-noise and anti-slip rubber finish. The supports are composed of polypropylene elements consisting of a cylindrical base with a minimum diameter of 205mm, a screw with an adjustable height from 15mm up to 270mm, equipped with an anti-screwing safety lock and a head equipped with N°4 spacer tabs with a thickness of either 2, 3, or 4mm and a height of 12mm easily removable if necessary. In the base there are holes for the outflow of water and N°2 grooves to facilitate the manual cutting if needed. The height adjustment is carried out using the tailored adjustment key, which acts on the screw independently from both the head and the base. It is possible to increase the height of the supports by using the PNM extension. Slope compensation is performed by using the TWIST TW compensator.

CHARACTERISTICS:

- Adjustable in height
- Bi-component material head (PP and rubber)
- Tailored key for height adjustment
- Easy removable tabs
- Anti-screwing safety lock
- manually fracturable base

RAW MATERIAL:

Polypropylene and rubber (head top finishing)

ENVIRONMENTAL IMPACT:

recyclable material - not dangerous

APPLICATIONS SURFACES:

- On any waterproofing membrane
- On any insulating hard panel
- On any compact and solid surface

APPLICATIONS AREA:

Can be used with any prefabricated self supporting element for outdoor flooring

GENERAL CHARACTERISTICS & PROPERTIES

	UNIT	VALUE	TOLERANCE +/-
BASE DIAMETER	mm	205	+/- 1.0
BASE THICKNESS	mm	2	+/- 0.2
HEAD DIAMETER	mm	110	+/- 0.8
SURFACE OF THE BASE	cmq	330	+/- 5
TABS THICKNESS	mm	2-3-4	+/- 0.2
TABS HEIGHT	mm	12	+/- 0.2
SHORE	Shore d	70	+/- 3
FIRE REACTION*	UNI-EN 13501-1:2009	CLASSE "E"	
LOW T(°C) REACTION	°C	-40	

*Tests made by Giordano S.p.A. Institute of Bellaria-Igea Marina (RN)-Italy



TECHNICAL DATA SHEET

PEDESTAL NM

eternoivica

INNOVATION LEADER



ITEMS CHARACTERISTICS & PROPERTIES

NM0_E014015027	UNIT	VALUE	TOLERANCE	PACK/STORAGE	
min HEIGHT	mm	15	+/- 1,0	PIECES PER BOX	20
MAX HEIGHT	mm	25	+/- 1,5	BOXES PER PALLET	84
WEIGHT	kg	0.16	+/- 5 %	BOX DIMENSION	40x40x14 cm
MAX CENTRAL COMPRESSION RESISTANCE**	kN	16.5	/	BOX WEIGHT	3.5kg
				PALLET	80x120cm
				PCS PER PALLET	1680

NM1_E014025047	UNIT	VALUE	TOLERANCE	PACK/STORAGE	
min HEIGHT	mm	25	+/- 1,0	PIECES PER BOX	20
MAX HEIGHT	mm	40	+/- 1,5	BOXES PER PALLET	66
WEIGHT	kg	0.212	+/- 5 %	BOX DIMENSION	39.5x39.5x20cm
MAX CENTRAL COMPRESSION RESISTANCE*	kN	31.18	/	BOX WEIGHT	4.5kg
MAX ECCENTRIC COMPRESSION RESISTANCE*	kN	15.19	/	PALLET	80x120cm
				PCS PER PALLET	1320

NM2_E014040077	UNIT	VALUE	TOLERANCE	PACK/STORAGE	
min HEIGHT	mm	40	+/- 1,0	PIECES PER BOX	20
MAX HEIGHT	mm	70	+/- 1,5	BOXES PER PALLET	48
WEIGHT	kg	0.276	+/- 5 %	BOX DIMENSION	40x40x27cm
MAX CENTRAL COMPRESSION RESISTANCE*	kN	38.67	/	BOX WEIGHT	5.8kg
MAX ECCENTRIC COMPRESSION RESISTANCE*	kN	21.48	/	PALLET	80x120cm
				PCS PER PALLET	960

NM3_E014060107	UNIT	VALUE	TOLERANCE	PACK/STORAGE	
min HEIGHT	mm	60	+/- 1,0	PIECES PER BOX	20
MAX HEIGHT	mm	100	+/- 1,5	BOXES PER PALLET	36
WEIGHT	kg	0.341	+/- 5 %	BOX DIMENSION	40x40x37cm
MAX CENTRAL COMPRESSION RESISTANCE*	kN	46.53	/	BOX WEIGHT	7.1kg
MAX ECCENTRIC COMPRESSION RESISTANCE*	kN	26.07	/	PALLET	80x120cm
				PCS PER PALLET	720

NM4_E014090167	UNIT	VALUE	TOLERANCE	PACK/STORAGE	
min HEIGHT	mm	90	+/- 1,0	PIECES PER BOX	20
MAX HEIGHT	mm	160	+/- 1,5	BOXES PER PALLET	30
WEIGHT	kg	0.43	+/- 5 %	BOX DIMENSION	40x40x42cm
MAX CENTRAL COMPRESSION RESISTANCE*	kN	29.57	/	BOX WEIGHT	8.9kg
MAX ECCENTRIC COMPRESSION RESISTANCE*	kN	16.75	/	PALLET	80x120cm
				PCS PER PALLET	600

NM5_E014150277	UNIT	VALUE	TOLERANCE	PACK/STORAGE	
min HEIGHT	mm	150	+/- 1,0	PIECES PER BOX	20
MAX HEIGHT	mm	270	+/- 1,5	BOXES PER PALLET	21
WEIGHT	kg	0.61	+/- 5 %	BOX DIMENSION	32x80x40cm
MAX CENTRAL COMPRESSION RESISTANCE*	kN	28.60	/	BOX WEIGHT	12.5kg
MAX ECCENTRIC COMPRESSION RESISTANCE*	kN	18.89	/	PALLET	80x120cm
				PCS PER PALLET	420

*Tests made by Civil and Environmental Department of University of Padova. 1 kN = 102 kg

**Tests made by the ECAMRICERT S.R.L. Research and Analysis Laboratory (1 kN = 102 kg)

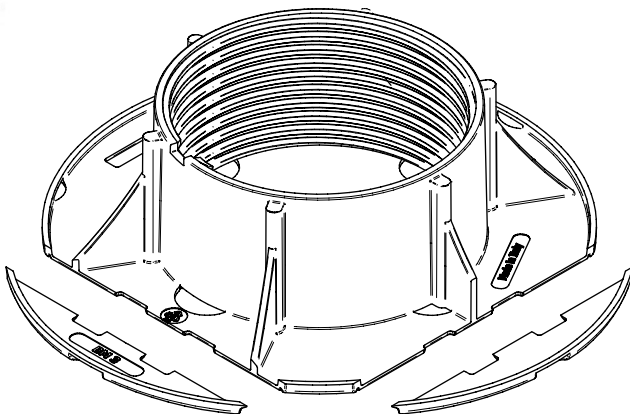
NEW**FRACTURABLE BASE:**

The base has 2 pre-cuts from which it is possible to split the extra base part by hand when laying on the wall edges or risers, without the need for auxiliary tools.

SUPPORTING RIBS:

The supporting ribs give a stable support during the installation of the vertical perimeter profiles

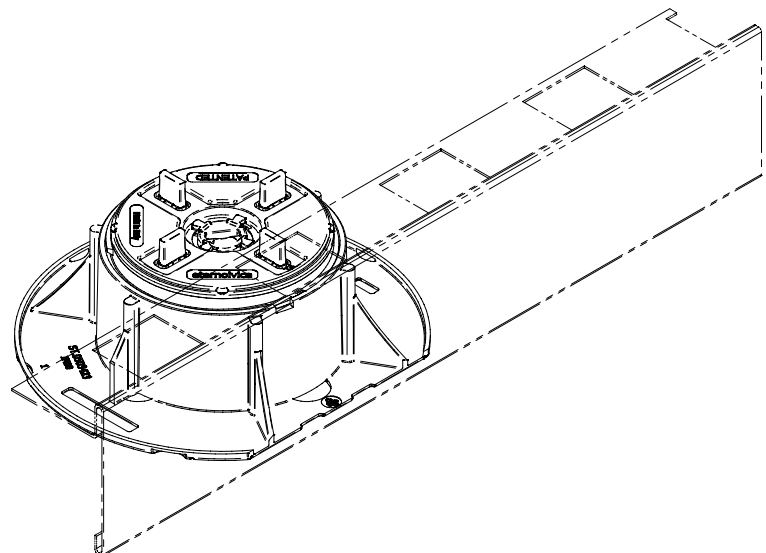

The packaging of the supports consists of cardboard boxes. The final packaging of the pallets is made with the wrapping of a polyethylene film. Indoor storage, protected from precipitation, is recommended.

INSTALLATION METHOD: The product is laid dry, without the need for adhesives or other types of fixings.

The above data are relevant to current production and may be changed or updated by Eterno Ivica at any time without notice. Given the many possible uses and the possible interference of external elements, we do not assume responsibility for the results. The buyer is required to establish under their own responsibility the suitability of the product for the intended use. This document is property of Eterno Ivica. All rights reserved.